

# BULLDOG VALVE ROBOT

Motorized Ball Valve Controller

YOLINK

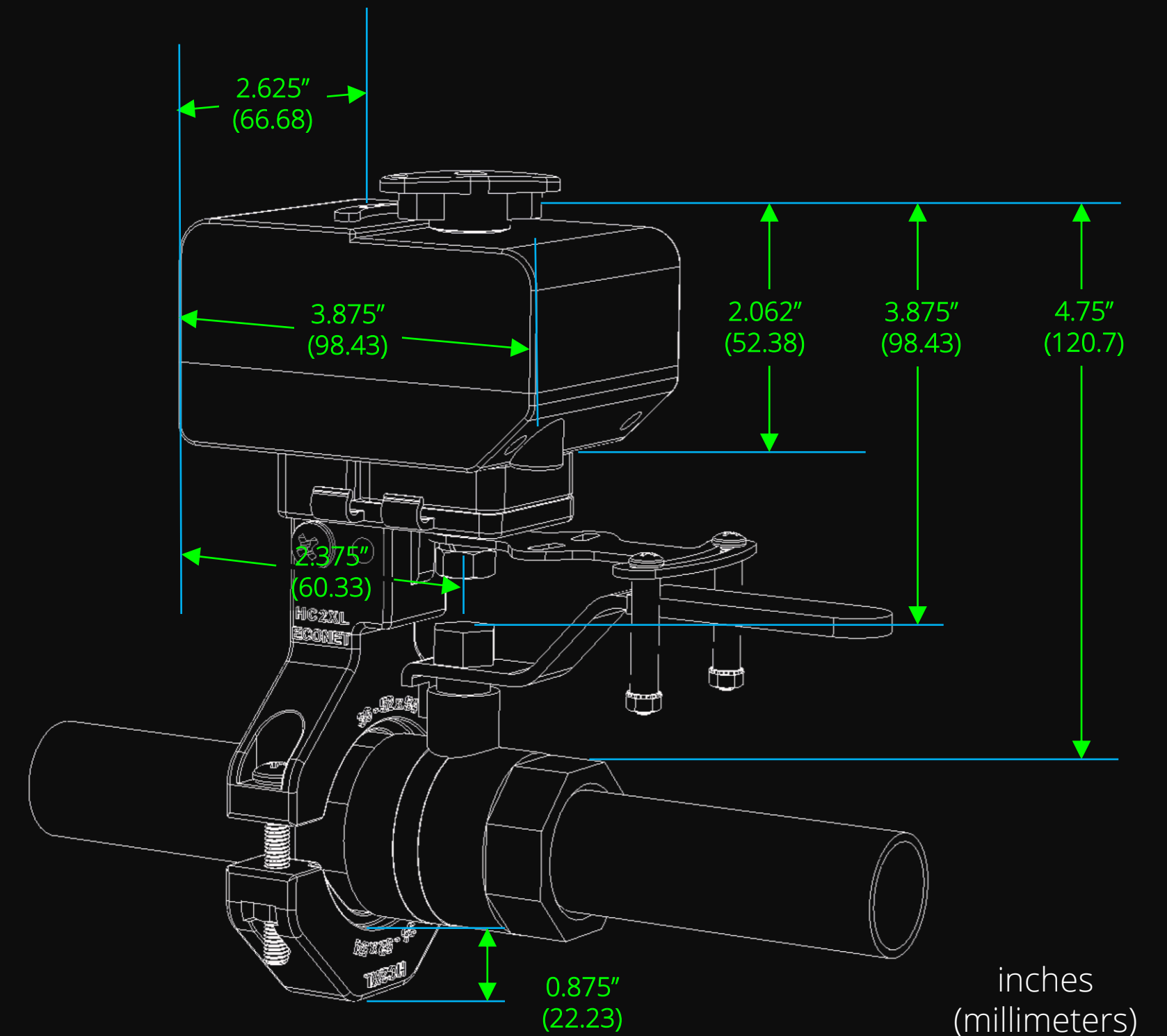
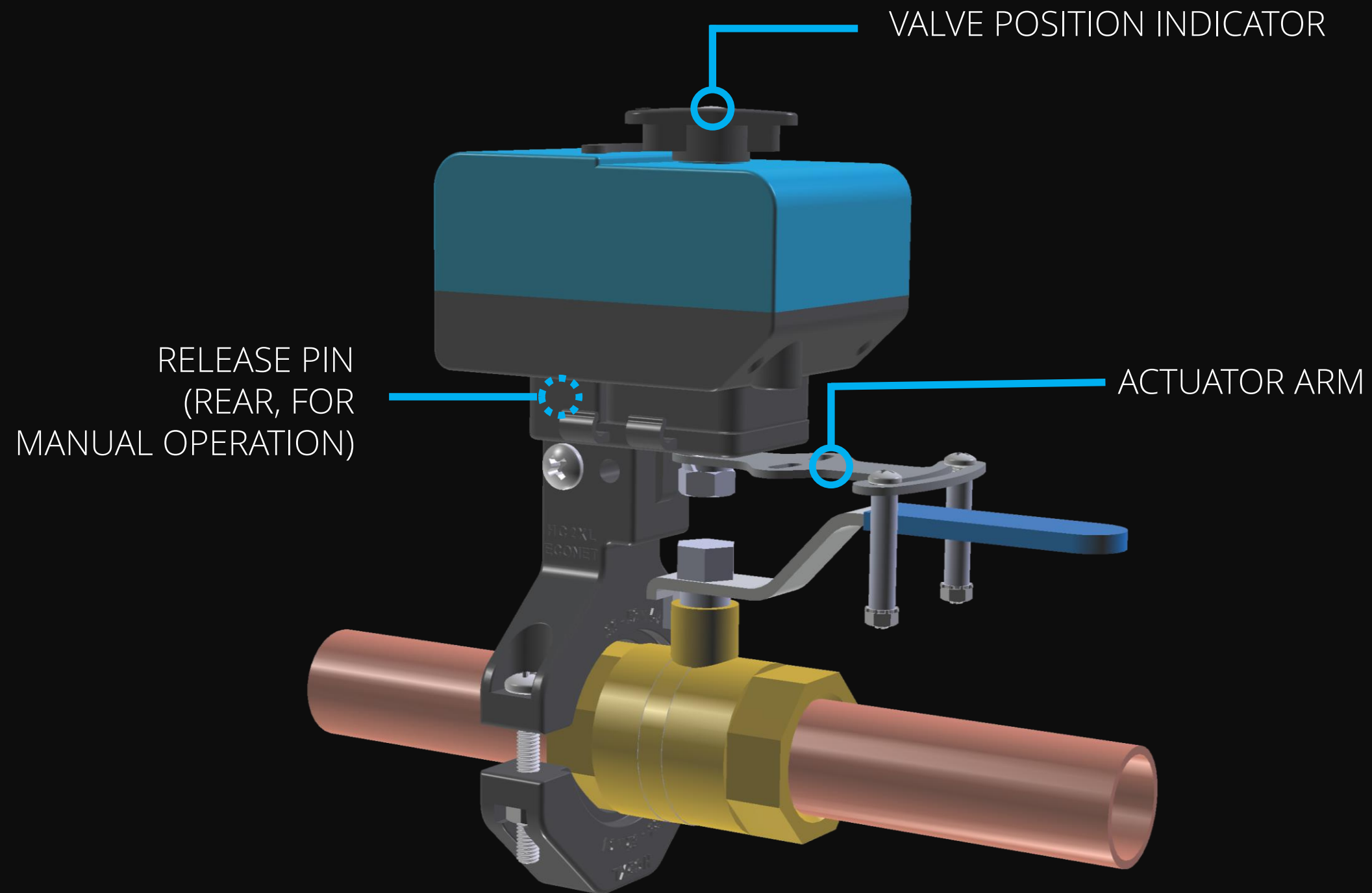

## SPECIFICATIONS:

**MOTOR:** High Torque Geared Valve Motor

**VOLTAGE:** 12VDC (Supplied by Controller, Required, Not Shown)

**HARNESS:** 2-Conductor Cable, 28" (700mm) Long, w/Watertight Connector

**COMPATIBLE VALVES:** Supports 1/2", 3/4", 1", 1.25" and 1.5" Ball Valves

**ENVIRONMENTAL:** 32 to 122°F (0 to 50°C)

## REMARKS:

- 1) Provide Overhead Cover if Installing Outdoors
- 2) Ball Valves Only
- 3) Valve Must Be in Good Working Order & Move Smoothly
- 4) 1/2" Solder & Crimp/PEX Valves May Require Optional HC2S Bracket. Refer to Website For Valve Compatibility Lists